

## Fast Voltage Transients in Capacitive Silicon-to-Cell Stimulation Detected with a Luminescent Molecular Electronic Probe

Dieter Braun and Peter Fromherz\*

Department of Membrane and Neurophysics, Max Planck Institute for Biochemistry, D-82152 Martinsried/München, Germany  
(Received 28 June 2000)

The capacitive stimulation of nerve cells from semiconductor chips is a prerequisite for the development of neuroelectronic devices. We report on the primary response of a cell membrane to a voltage step applied to oxidized silicon. It is observed with a luminescent voltage-sensitive dye. We find exponential voltage transients with a time constant of 1–5  $\mu\text{s}$ . We assign the short response to an electrical decoupling by a thin film of electrolyte between oxide and membrane. The high-pass filtering of stimulation is a crucial constraint for the development of silicon-to-neuron interfaces.

DOI: 10.1103/PhysRevLett.86.2905

PACS numbers: 87.50.Rr, 78.20.Jq, 87.80.Xa

**Introduction.**—The direct electrical interfacing of microstructured semiconductor chips with individual nerve cells is an elementary step towards a development of hybrid neuroelectronic systems. Both directions of coupling were implemented recently from an excited leech neuron to an open field-effect transistor [1] and from spots of oxidized silicon to a leech neuron by capacitive stimulation [2]. An optimization of interfacing—in particular, with small mammalian neurons [3]—requires an analysis of the electrical dynamics of the cell-semiconductor contact. In the present paper, we describe the response of a cell membrane to capacitive stimulation on a silicon chip using an optoelectronic approach with luminescent voltage-sensitive dye molecules.

**Problem.**—When a voltage step is applied to oxidized highly doped silicon with an attached cell, we expect a polarization of oxide and cell membrane as indicated by the capacitors in the circuit of Fig. 1(a). Subsequently, the membrane can discharge through a resistor given by a film of electrolyte between oxide and membrane [4]. The dynamics of the voltage across the attached membrane  $V_{JM} = V_M - V_J$  (potentials  $V_M$  and  $V_J$  in cell and junction) is determined by Eq. (1) with the capacitances  $c_{OX}$  and  $c_M$  per unit area of oxide and membrane and the conductance  $g_J$  per unit area of the electrolyte film:

$$[c_M + (1 + \beta_M)c_{OX}] \frac{dV_{JM}}{dt} + (1 + \beta_M)g_J V_{JM} = -c_{OX} \frac{dV_{SB}}{dt}. \quad (1)$$

$\beta_M = A_{JM}/A_{FM} < 1$  is the ratio of attached and free membrane area, and  $V_{SB} = V_S - V_B$  is the voltage applied between solid and bath (potentials  $V_S$  and  $V_B$  in silicon and bath). The response of the free membrane  $V_{FM} = V_M - V_B$  is weaker with inverted sign:

$$\frac{dV_{FM}}{dt} = -\beta_M \frac{dV_{JM}}{dt}. \quad (2)$$

For a stimulation step  $V_{SB}(t) = V_{SB}^0 \Theta(t)$ , the exponential response is given by Eqs. (3) with the capacitive transfer

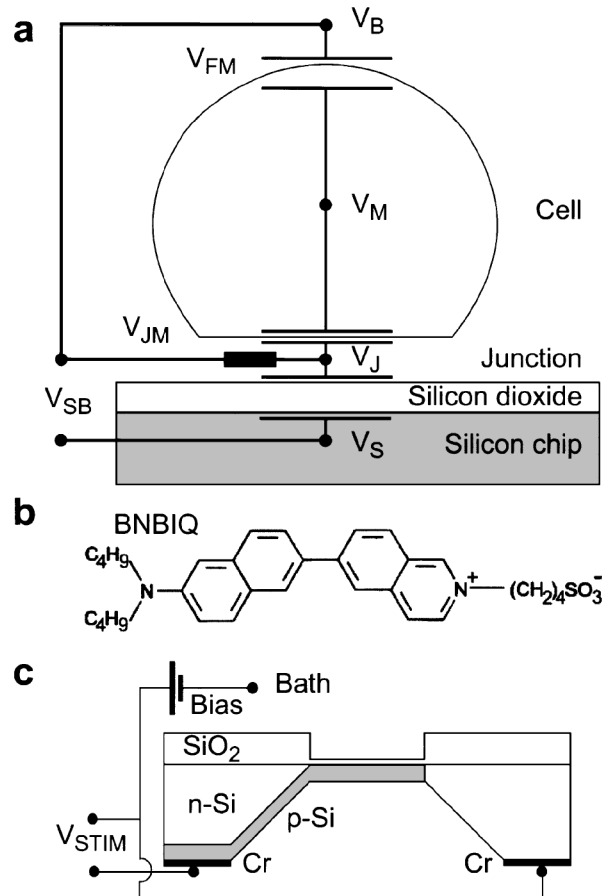

FIG. 1. Silicon-to-cell stimulation. (a) A cell (diameter about 20  $\mu\text{m}$ ) is attached to oxidized silicon, separated by a film of electrolyte (thickness about 50 nm). The silicon dioxide, the attached membrane, and the free cell membrane are described by capacitors, the film of electrolyte by an Ohmic resistor. A voltage  $V_{SB}$  is applied between chip and bath. The voltage transients  $V_{JM}$  and  $V_{FM}$  across the attached and free membrane are converted to fluorescence transients by a voltage-sensitive dye. (b) The amphiphilic hemicyanine dye BNBIQ is adsorbed to the outer surface of the cell membrane. (c) Chip. The  $p$ -doped stimulation area is insulated with 50 nm  $\text{SiO}_2$ . It is contacted from the back through an etched and  $p$ -doped pyramidal well at chromium pads. Voltage pulses  $V_{STIM}$  between stimulation spot and bath are applied through a bias voltage.

$h_{JM}^\infty$  and the time constant  $\tau_J$  according to Eqs. (4):

$$V_{JM} = V_{SB}^0 h_{JM}^\infty \exp(-t/\tau_J), \quad (3)$$

$$V_{FM} = -V_{SB}^0 \beta_M h_{JM}^\infty \exp(-t/\tau_J),$$

$$h_{JM}^\infty = -\frac{c_{OX}}{c_M + (1 + \beta_M)c_{OX}}, \quad (4)$$

$$\tau_J = \frac{c_M + (1 + \beta_M)c_{OX}}{(1 + \beta_M)g_J}.$$

The problem is to measure the voltage transients predicted by Eqs. (3) and to check whether the experimental data are compatible with the features of the junction as expressed by Eqs. (4). As the cell-silicon junction is an extended core-coat conductor [4], the parameters  $h_{JM}^\infty$ ,  $g_J$ , and  $\tau_J$  depend on the position in a space-resolved measurement.

*Dye.*—To observe  $V_{JM}(t)$  and  $V_{FM}(t)$ , we adsorb the dye dibutyl-naphthalin-butylsulfonato-isoquinolinium (BNBIQ) [Fig. 2(b)] [5,6] to the surface of the cell. Similar hemicyanines have been used for recording action potentials in nerve and muscle cells [7–11]. They exhibit an intramolecular displacement of electrical charge by electronic excitation [9,12] and by twist in the excited state [13]. If the chromophore is oriented along the membrane normal [14], the interaction with an electrical field across the membrane leads to a shift of the absorption and emission spectra and to a modulation of the decay with a response time in the nanosecond range. A change of the membrane voltage gives rise to a proportional change of the stationary fluorescence intensity at given wavelengths of illumination and detection. For BNBIQ in leech neurons, the relative change is up to  $S_{DYE} \approx -10\%/100 \text{ mV}$  [6].

In probing voltage-induced fluorescence transients in a cell-silicon contact, we are faced with two problems: (i) The changing electrical field in the membrane is normal to the chip, whereas the polarization of incident light in a microscope is rather parallel to the chip. As the transition dipoles and the intramolecular charge shifts are parallel, we expect a weak change of fluorescence intensity. Fortunately, the chromophores are not perfectly aligned along the membrane normal [15]. So a certain interaction both with the changing field and with the light wave is possible. (ii) A high voltage drop across the membrane requires a high capacitance of the chip, i.e., a thin layer of silicon dioxide. On the other hand, we expect a low fluorescence intensity on a thin oxide due to a node of the standing light modes near the surface of silicon [16,17]. Choosing an oxide with a modest thickness of 50 nm, we achieve sufficient stimulation and intensity.

*Chips.*—Silicon wafers (4 in.,  $\langle 100 \rangle$ , polished both sides, 400  $\mu\text{m}$  thick,  $n$ -doped, 2–4  $\Omega \text{ cm}$ , SicoWafer, Meinigen, Germany) are doped with boron for stimulation areas on the front and conduction paths on the back. Both are connected through doped pyramidal wells fabricated by anisotropic chemical etching [18,19] [Fig. 2(c)]. 1070 nm

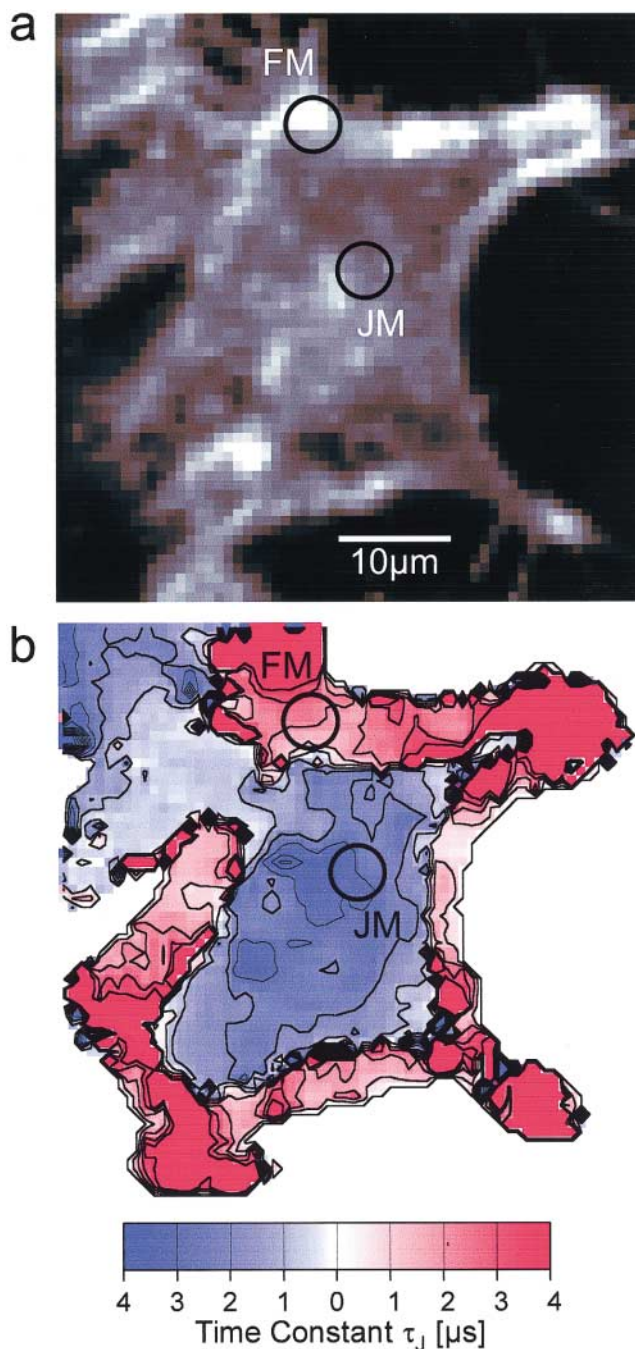

FIG. 2 (color). Fluorescence and electrical response of HEK293 cell stained with the dye BNBIQ. (a) Fluorescence intensity. The circles mark two areas of the attached membrane (JM) and of the free membrane (FM). (b) Map of time constants  $\tau_J$  of the optical transients after a positive voltage step applied to silicon. Red codes for positive voltage transients across the membrane (negative optical transients), blue for negative voltage transients (positive optical transients).

oxide is grown. The stimulation areas ( $560 \times 560 \mu\text{m}^2$ ) are opened and oxidized dry to 50 nm (breakthrough voltage  $>10 \text{ V}$ ) [2]. Contact pads are opened on the back and metallized with chromium. The chips are glued on 35 mm plastic dishes (Falcon 3001, Becton Dickinson, Heidelberg) with a silicon glue (MK3, Sulzer Medica GmbH,

Köln) and contacted from the back by gilded springs. They are wiped with detergent (2% Tickopur RP100, Bandelin, Berlin) at 60 °C, rinsed with milli-Q water, dried with nitrogen, sterilized by UV (30 min), and coated with fibronectin (Sigma, 25  $\mu\text{g}/\text{ml}$  in PBS overnight).

**Cells.**—We use human embryonic kidney cells (HEK293, CRL-1573, ATCC, Manassas, Virginia) which have a smooth membrane with a low conductance [20,21]. They are cultured in 3 ml of 13.9 mg/ml Dulbecco's medium (DMEM, 074-02100A, Gibco) with 10% heat inactivated fetal bovine serum (FBS, Seromed, Berlin) 3.7 mg/ml  $\text{NaHCO}_3$  (Sigma), 4 mM *L*-glutamine, and 25 U/ml penicillin and streptomycin (Gibco) at pH 6.8 (37 °C, 5%  $\text{CO}_2$ ) for 2–3 days to 50% confluence. To stain with BNBIQ, 40  $\mu\text{l}$  of a centrifuged, saturated solution in a 1:1 mixture of FBS and milli-Q water is added. The cells are measured within 30 min after staining.

**Setup.**—A confocal microscope (FluoView 1.26, Olympus with 40 $\times$  UApo/340, NA 1.15) is used to select the recording position and to suppress the fluorescence from the upper membrane. On the basis of spectral data of BNBIQ [22], an excitation at 488 nm (Ar laser, Stabilite 2017, Spectra Physics) and a detection between 590–700 nm (bandpass filter, AHF, Tübingen) is chosen. The photomultiplier signal  $V_{PM}$  (R928, Hamamatsu; built-in amplifier, Olympus) is sampled at 5 MHz with 12 bit (PCI 6110E, National Instruments) and corrected for background. The transfer function  $h_{PM} = V_{PM}/F$  (light intensity  $F$ ) is obtained with a light-emitting diode and a fit with a Bessel filter of order 4 (cutoff at 615 kHz). Rectangular voltage pulses  $V_{STIM}$  with an amplitude of  $-6$  V and a width of 12  $\mu\text{s}$  (function generator HP 33120A, Hewlett Packard) are applied to a stimulation spot with respect to bulk silicon, both biased by  $+7$  V with respect to a platinum electrode (area 2  $\text{cm}^2$ ) in the bath. The setup is controlled by LabView. The transients are fitted by trial functions  $[V_{PM}(t) - \bar{V}_{PM}]/\bar{V}_{PM}$  (average  $\bar{V}_{PM}$ ), obtained in Fourier space with the chip transfer  $V_{SB}/V_{STIM} = h_{CHIP} = (1 + i\omega 0.06 \mu\text{s})^{-1}$ , the response of the membranes  $V_{JM}/V_{SB} = h_{JM} = i\omega\tau_J h_{JM}^\infty / (1 + i\omega\tau_J)$  or  $V_{FM}/V_{SB} = h_{FM} = -\beta_M h_{JM}$ , the relative sensitivity of the dye  $S_{DYE}$ , and the transfer  $h_{PM}$  of the photomultiplier:

$$[V_{PM}(\omega) - \bar{V}_{PM}]/\bar{V}_{PM} = h_{PM}(\omega) S_{DYE} h_{JM}(\omega) \times h_{CHIP}(\omega) V_{STIM}(\omega). \quad (5)$$

**Fluorescence transients.**—The fluorescence picture of a stained HEK293 cell is shown in Fig. 2(a). The staining with BNBIQ is inhomogeneous, probably due to internalization of the dye by the cell. Local background fluorescence lowers the sensitivity of the dye. A train of voltage pulses  $V_{STIM}$  with an amplitude of  $-6$  V and a width of 12  $\mu\text{s}$  [Fig. 3(a)] is applied to the stimulation spot beneath the cell. We record the optical response by averaging 800 optical transients at each pixel of the image. For two selected sites marked in Fig. 2(a), the relative response  $[V_{PM}(t) - \bar{V}_{PM}]/\bar{V}_{PM}$  is shown in

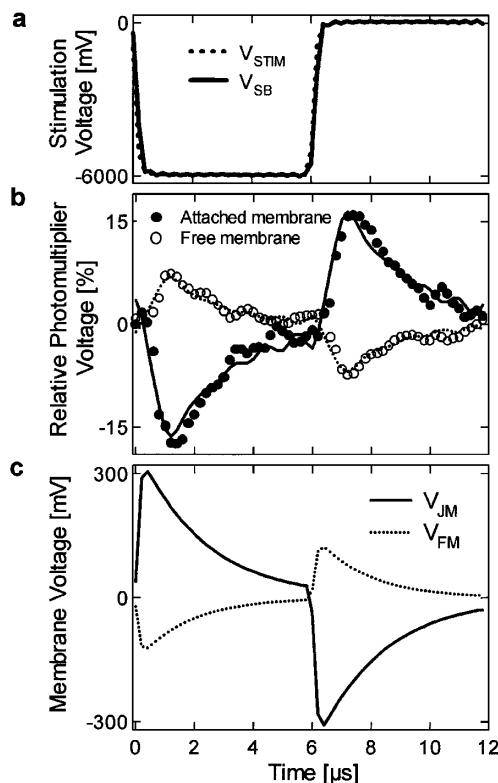

FIG. 3. Selected optical records. (a) Stimulation voltage  $V_{STIM}$  and voltage change  $V_{SB}$  between silicon and bath. (b) Transients of relative response of the optical recording (photomultiplier voltage) for attached (region JM in Fig. 2) and free (region FM) membrane. The data are fitted according to Eqs. (3) and (5) with time constants 2.9  $\mu\text{s}$  (attached) and 2.2  $\mu\text{s}$  (free), including the convolution with the response functions of stimulation and recording. (c) Membrane voltages in the attached and free membrane  $V_{JM}$  and  $V_{FM}$  reconstructed from the optical records.

Fig. 3(b), one near the center of the adhesion area and one in the periphery where the free membrane bulges upwards. The positive voltage step leads to fluorescence changes of  $+15\%$  in the attached membrane and of  $-7\%$  in the free membrane. The decay time of both transients is a few microseconds. We fit the data with exponentials according to Eqs. (3) and (5) with two parameters. For the attached membrane, we obtain  $\tau_J = 2.9 \pm 0.4 \mu\text{s}$  and  $S_{DYE} h_{JM}^\infty = 0.37\%/100 \text{ mV}$ , for the free membrane  $\tau_J = 2.2 \pm 0.4 \mu\text{s}$  and  $-\beta_M S_{DYE} h_{JM}^\infty = -0.16\%/100 \text{ mV}$  [Fig. 3(b)]. The delayed rise of the optical transients is due to the low-pass filtering of detection.

A map of the time constant is shown in Fig. 2(b) for a positive step of stimulation. A large area with positive optical amplitude marks the region of cell adhesion which is not obscured by the surrounding ribbon with a negative optical amplitude where the membrane is detached but still in focus. The time constant is up to 4  $\mu\text{s}$  in the area of adhesion and drops to values below 1  $\mu\text{s}$  near the edge. In the region of the free membrane, the amplitudes are usually weak and the fit of the time constant is not reliable. Transients with low noise have a time constant around 2.4  $\mu\text{s}$ . The corridor of positive optical amplitude in the

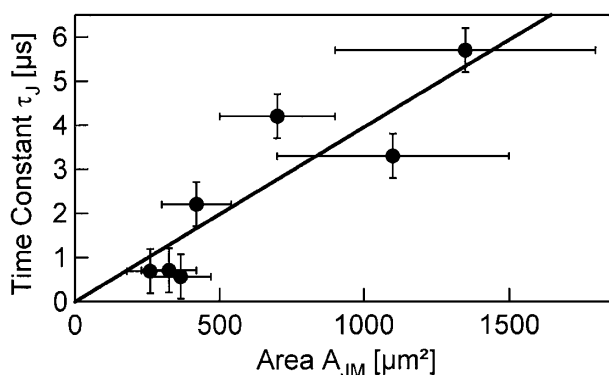

FIG. 4. Time constants  $\tau_J$  of optical transients near the center of adhesion of HEK293 cells versus the area  $A_{JM}$  of adhesion. The regression line has a slope of  $\tau_J/A_{JM} = 4.0 \text{ ns}/\mu\text{m}^2$ .

left upper corner is due to a second cell that is closely attached with the adhesion area extending beneath both cells.

There is a variability of the observed time constants with a distinct correlation to the size of the adhesion area as shown in Fig. 4 for positions near the center. The regression line has a slope of  $\tau_J/A_{JM} = 4.0 \text{ ns}/\mu\text{m}^2$ .

*Amplitude.*—The amplitudes  $S_{\text{DYE}}h_{JM}^\infty$  and  $-\beta_M \times S_{\text{DYE}}h_{JM}^\infty$  are determined by the sensitivity  $S_{\text{DYE}}$ , the area ratio  $\beta_M$ , and the capacitances  $c_{\text{OX}}$  and  $c_M$  according to Eq. (4). With  $c_{\text{OX}} = 0.07 \mu\text{F}/\text{cm}^2$ ,  $c_M = 1 \mu\text{F}/\text{cm}^2$ , and  $\beta_M = 0.4$  estimated from a 3D laser scan of the cell, and with  $S_{\text{DYE}} = -6.2\%/100 \text{ mV}$  measured in HEK293 cells with intracellular dc voltage [22], we obtain  $S_{\text{DYE}}h_{JM}^\infty = 0.4\%/100 \text{ mV}$  and  $-\beta_M S_{\text{DYE}}h_{JM}^\infty = -0.16\%/100 \text{ mV}$ . These values are in good agreement with the experiment. The coincidence indicates that the fluorescence change is really caused by capacitive coupling of silicon and membrane. The reconstructed traces of the membrane voltages  $V_{JM}(t)$  and  $V_{FM}(t)$  in the selected areas are shown in Fig. 3(c). For a voltage step  $V_{SB}(t) = +6 \text{ V}$ , the amplitudes are  $-300$  and  $+120 \text{ mV}$ , respectively, well below the breakthrough voltage of cell membranes [23].

*Time constant.*—According to Eq. (4), the time constant  $\tau_J$  depends on  $c_{\text{OX}}$ ,  $c_M$ ,  $\beta_M$ , and the specific conductance  $g_J$  of the electrolyte film. For a circular contact, the latter can be written as  $g_J = \text{const} \times d_J/\rho_J a_J^2$ , with the radius  $a_J$  and the thickness  $d_J$  of the electrolyte film with a specific resistance  $\rho_J$  [4]. The distance between HEK293 cells and chips coated with fibronectin is  $d_J = 50 \pm 6 \text{ nm}$  (24 cells) as measured by fluorescence interference contrast (FLIC) microscopy [16,17]. With  $\rho_J = 74 \Omega \text{ cm}$  of the bath and with an estimated  $\text{const} = 5$  [4], we obtain a ratio of time constant and area  $\tau_J/\pi a_J^2 = 7.25 \text{ ns}/\mu\text{m}^2$ . The similarity to the experimental slope indicates that the short transients are really caused by a decoupling film of electrolyte. The difference shows that the specific resistance of this film might be lowered by a factor of 2 as compared with the bath. A quantitative evaluation of this effect will require detailed studies by ac stimulation taking into account the space-resolved dynamics of the junction.

*Conclusion.*—In the present study, fluorescent voltage-sensitive dyes demonstrate their potential to monitor fast electrical polarizations near a semiconductor. They record the primary response of a cell to the capacitive stimulus from oxidized silicon. The time constant of the voltage transient is in the microsecond range owing to the decoupling of chip and cell by a thin film of electrolyte. The high-pass coupling raises the following question: How can we achieve an electronic control of ion channels and other molecules in a cell membrane where the typical time constants are in the millisecond range?

We thank Bernd Kuhn for advice about the voltage-sensitive dye, Bernhard Straub for his expertise with back-bonding, Helge Vogl and Christian Figger for help in chip fabrication, and Martin Maass from Olympus for fruitful cooperation. The project was supported by the Bundesministerium für Bildung und Forschung.

\*Author to whom correspondence should be addressed.

Electronic address: fromherz@biochem.mpg.de

- [1] P. Fromherz, A. Offenhäusser, T. Vetter, and J. Weis, *Science* **252**, 1290 (1991).
- [2] P. Fromherz and A. Stett, *Phys. Rev. Lett.* **75**, 1670 (1995).
- [3] S. Vassanelli and P. Fromherz, *Appl. Phys. A* **66**, 459 (1998).
- [4] R. Weis and P. Fromherz, *Phys. Rev. E* **55**, 877 (1997).
- [5] H. Ephardt and P. Fromherz, *J. Phys. Chem.* **97**, 4540 (1993).
- [6] P. Fromherz and C. O. Müller, *Biochim. Biophys. Acta* **1150**, 111 (1993).
- [7] L. B. Cohen and B. M. Salzberg, *Rev. Physiol. Biochem. Pharmacol.* **83**, 35 (1978).
- [8] A. Grinvald, A. Fine, I. C. Farber, and R. Hildesheim, *Biophys. J.* **42**, 195 (1983).
- [9] E. Fluhler, V. G. Burnham, and L. M. Loew, *Biochemistry* **24**, 5749 (1985).
- [10] P. Fromherz and T. Vetter, *Proc. Natl. Acad. Sci. U.S.A.* **89**, 2041 (1992).
- [11] S. Rohr and B. M. Salzberg, *Biophys. J.* **67**, 1301 (1994).
- [12] P. Fromherz, *J. Phys. Chem.* **99**, 7188 (1995).
- [13] C. Röcker, A. Heilemann, and P. Fromherz, *J. Phys. Chem.* **100**, 12 172 (1996).
- [14] L. M. Loew and L. L. Simpson, *Biophys. J.* **34**, 353 (1981).
- [15] A. Lambacher and P. Fromherz, *J. Phys. Chem.* **105**, 343 (2001).
- [16] A. Lambacher and P. Fromherz, *Appl. Phys. A* **63**, 207 (1996).
- [17] D. Braun and P. Fromherz, *Phys. Rev. Lett.* **81**, 5241 (1998).
- [18] H. Seidel *et al.*, *J. Electrochem. Soc.* **137**, 3512 (1990).
- [19] P. Fromherz and J. Klingler, *Biochim. Biophys. Acta* **1062**, 103 (1991).
- [20] F. L. Graham, J. Smiley, W. C. Russel, and R. Nairn, *J. Gen. Virol.* **36**, 59 (1977).
- [21] G. Zhu, Y. Zhang, H. Xu, and C. J. Jiang, *Neurosci. Meth.* **81**, 73 (1998).
- [22] B. Kuhn and P. Fromherz (unpublished).
- [23] R. Benz, F. Beckers, and U. Zimmermann, *J. Membr. Biol.* **49**, 181 (1979).